



US009741282B2

(12) **United States Patent**
Giannikouris et al.

(10) **Patent No.:** **US 9,741,282 B2**
(45) **Date of Patent:** **Aug. 22, 2017**

(54) **OLED DISPLAY SYSTEM AND METHOD**

(71) Applicant: **Ignis Innovation Inc.**, Waterloo (CA)

(72) Inventors: **Allyson Giannikouris**, Kitchener (CA);
Jaimal Soni, Waterloo (CA); **Nino Zahirovic**, Waterloo (CA); **Ricky Yik Hei Ngan**, Richmond Hills (CA);
Gholamreza' Chaji, Waterloo (CA)

(73) Assignee: **Ignis Innovation Inc.**, Waterloo (CA)

(*) Notice: Subject to any disclaimer, the term of this patent is extended or adjusted under 35 U.S.C. 154(b) by 135 days.

(21) Appl. No.: **14/561,404**

(22) Filed: **Dec. 5, 2014**

(65) **Prior Publication Data**

US 2015/0161935 A1 Jun. 11, 2015

Related U.S. Application Data

(60) Provisional application No. 61/976,909, filed on Apr. 8, 2014, provisional application No. 61/912,786, filed on Dec. 6, 2013.

(51) **Int. Cl.**

G09G 3/20 (2006.01)
G09G 3/3208 (2016.01)
G09G 3/3233 (2016.01)

(52) **U.S. Cl.**

CPC **G09G 3/2074** (2013.01); **G09G 3/2003** (2013.01); **G09G 3/3208** (2013.01); **G09G 3/3233** (2013.01); **G09G 2300/0452** (2013.01); **G09G 2300/0852** (2013.01); **G09G 2320/0238** (2013.01); **G09G 2320/0276** (2013.01);

(Continued)

(58) **Field of Classification Search**

None
See application file for complete search history.

(56) **References Cited**

U.S. PATENT DOCUMENTS

3,506,851 A 4/1970 Polkinghorn
3,774,055 A 11/1973 Bapat
(Continued)

FOREIGN PATENT DOCUMENTS

CA 1 294 034 1/1992
CA 2 109 951 11/1992
(Continued)

OTHER PUBLICATIONS

Ahnood : "Effect of threshold voltage instability on field effect mobility in thin film transistors deduced from constant current measurements"; dated Aug. 2009.

(Continued)

Primary Examiner — Shaheda Abdin

(74) *Attorney, Agent, or Firm* — Nixon Peabody LLP

(57) **ABSTRACT**

A method and system control an OLED display to achieve desired color points and brightness levels in an array of pixels in which each pixel includes at least three sub-pixels having different colors and at least one white sub-pixel. The method and system select a plurality of reference points in the pixel content domain with known color points and brightness levels. For each set of three sub-pixels of different colors, the method and system determine the share of each sub-pixel to produce the color point and brightness level of each selected reference point, and select the maximum share determined for each sub-pixel as peak brightness needed from that sub-pixel.

14 Claims, 7 Drawing Sheets

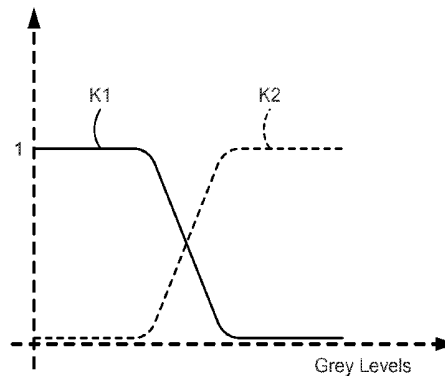
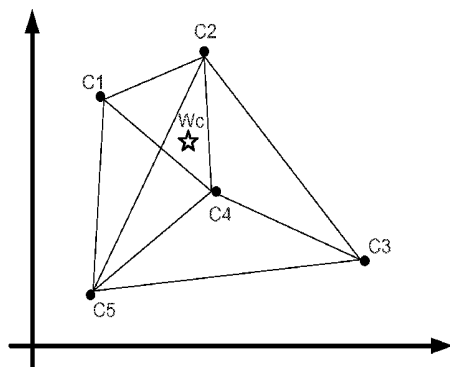

(52)	U.S. Cl.		6,531,827 B2	3/2003	Kawashima
	CPC	G09G 2320/0673 (2013.01); G09G 2330/021 (2013.01); G09G 2340/06 (2013.01)	6,542,138 B1	4/2003	Shannon
			6,555,420 B1	4/2003	Yamazaki
			6,580,408 B1	6/2003	Bae
			6,580,657 B2	6/2003	Sanford
			6,583,398 B2	6/2003	Harkin
			6,583,775 B1	6/2003	Sekiya
			6,594,606 B2	7/2003	Everitt
			6,618,030 B2	9/2003	Kane
			6,639,244 B1	10/2003	Yamazaki
			6,668,645 B1	12/2003	Gilmour
			6,677,713 B1	1/2004	Sung
			6,680,580 B1	1/2004	Sung
			6,687,266 B1	2/2004	Ma
			6,690,000 B1	2/2004	Muramatsu
			6,690,344 B1	2/2004	Takeuchi
			6,693,388 B2	2/2004	Oomura
			6,693,610 B2	2/2004	Shannon
			6,697,057 B2	2/2004	Koyama
			6,720,942 B2	4/2004	Lee
			6,724,151 B2	4/2004	Yoo
			6,734,636 B2	5/2004	Sanford
			6,738,034 B2	5/2004	Kaneko
			6,738,035 B1	5/2004	Fan
			6,753,655 B2	6/2004	Shih
			6,753,834 B2	6/2004	Mikami
			6,756,741 B2	6/2004	Li
			6,756,952 B1	6/2004	Decaux
			6,756,958 B2	6/2004	Furuhashi
			6,771,028 B1	8/2004	Winters
			6,777,712 B2	8/2004	Sanford
			6,777,888 B2	8/2004	Kondo
			6,781,567 B2	8/2004	Kimura
			6,806,497 B2	10/2004	Jo
			6,806,638 B2	10/2004	Lin
			6,806,857 B2	10/2004	Sempel
			6,809,706 B2	10/2004	Shimoda
			6,815,975 B2	11/2004	Nara
			6,828,950 B2	12/2004	Koyama
			6,853,371 B2	2/2005	Miyajima
			6,859,193 B1	2/2005	Yumoto
			6,873,117 B2	3/2005	Ishizuka
			6,876,346 B2	4/2005	Anzai
			6,885,356 B2	4/2005	Hashimoto
			6,900,485 B2	5/2005	Lee
			6,903,734 B2	6/2005	Eu
			6,909,243 B2	6/2005	Inukai
			6,909,419 B2	6/2005	Zavracky
			6,911,960 B1	6/2005	Yokoyama
			6,911,964 B2	6/2005	Lee
			6,914,448 B2	7/2005	Jinno
			6,919,871 B2	7/2005	Kwon
			6,924,602 B2	8/2005	Komiya
			6,937,215 B2	8/2005	Lo
			6,937,220 B2	8/2005	Kitaura
			6,940,214 B1	9/2005	Komiya
			6,943,500 B2	9/2005	LeChevalier
			6,947,022 B2	9/2005	McCartney
			6,954,194 B2	10/2005	Matsumoto
			6,956,547 B2	10/2005	Bae
			6,975,142 B2	12/2005	Azami
			6,975,332 B2	12/2005	Arnold
			6,995,510 B2	2/2006	Murakami
			6,995,519 B2	2/2006	Arnold
			7,023,408 B2	4/2006	Chen
			7,027,015 B2	4/2006	Booth, Jr.
			7,027,078 B2	4/2006	Reihl
			7,034,793 B2	4/2006	Sekiya
			7,038,392 B2	5/2006	Libsch
			7,057,359 B2	6/2006	Hung
			7,061,451 B2	6/2006	Kimura
			7,064,733 B2	6/2006	Cok
			7,071,932 B2	7/2006	Libsch
			7,088,051 B1	8/2006	Cok
			7,088,052 B2	8/2006	Kimura
			7,102,378 B2	9/2006	Kuo
			7,106,285 B2	9/2006	Naugler
			7,112,820 B2	9/2006	Chang
			7,116,058 B2	10/2006	Lo
(56)	References Cited				
	U.S. PATENT DOCUMENTS				
	4,090,096 A	5/1978 Nagami			
	4,160,934 A	7/1979 Kirsch			
	4,354,162 A	10/1982 Wright			
	4,943,956 A	7/1990 Noro			
	4,996,523 A	2/1991 Bell			
	5,153,420 A	10/1992 Hack			
	5,198,803 A	3/1993 Shie			
	5,204,661 A	4/1993 Hack			
	5,266,515 A	11/1993 Robb			
	5,489,918 A	2/1996 Mosier			
	5,498,880 A	3/1996 Lee			
	5,557,342 A	9/1996 Eto			
	5,572,444 A	11/1996 Lentz			
	5,589,847 A	12/1996 Lewis			
	5,619,033 A	4/1997 Weisfield			
	5,648,276 A	7/1997 Hara			
	5,670,973 A	9/1997 Bassetti			
	5,684,365 A	11/1997 Tang			
	5,691,783 A	11/1997 Numao			
	5,714,968 A	2/1998 Ikeda			
	5,723,950 A	3/1998 Wei			
	5,744,824 A	4/1998 Kousai			
	5,745,660 A	4/1998 Kolpatzik			
	5,748,160 A	5/1998 Shieh			
	5,815,303 A	9/1998 Berlin			
	5,870,071 A	2/1999 Kawahata			
	5,874,803 A	2/1999 Garbuzov			
	5,880,582 A	3/1999 Sawada			
	5,903,248 A	5/1999 Irwin			
	5,917,280 A	6/1999 Burrows			
	5,923,794 A	7/1999 McGrath			
	5,945,972 A	8/1999 Okumura			
	5,949,398 A	9/1999 Kim			
	5,952,789 A	9/1999 Stewart			
	5,952,991 A	9/1999 Akiyama			
	5,982,104 A	11/1999 Sasaki			
	5,990,629 A	11/1999 Yamada			
	6,023,259 A	2/2000 Howard			
	6,069,365 A	5/2000 Chow			
	6,091,203 A	7/2000 Kawashima			
	6,097,360 A	8/2000 Holloman			
	6,144,222 A	11/2000 Ho			
	6,177,915 B1	1/2001 Beeteson			
	6,229,506 B1	5/2001 Dawson			
	6,229,508 B1	5/2001 Kane			
	6,246,180 B1	6/2001 Nishigaki			
	6,252,248 B1	6/2001 Sano			
	6,259,424 B1	7/2001 Kurogane			
	6,262,589 B1	7/2001 Tamukai			
	6,271,825 B1	8/2001 Greene			
	6,288,696 B1	9/2001 Holloman			
	6,304,039 B1	10/2001 Appelberg			
	6,307,322 B1	10/2001 Dawson			
	6,310,962 B1	10/2001 Chung			
	6,320,325 B1	11/2001 Cok			
	6,323,631 B1	11/2001 Juang			
	6,356,029 B1	3/2002 Hunter			
	6,373,454 B1	4/2002 Knapp			
	6,392,617 B1	5/2002 Gleason			
	6,414,661 B1	7/2002 Shen			
	6,417,825 B1	7/2002 Stewart			
	6,433,488 B1	8/2002 Bu			
	6,437,106 B1	8/2002 Stoner			
	6,445,369 B1	9/2002 Yang			
	6,475,845 B2	11/2002 Kimura			
	6,501,098 B2	12/2002 Yamazaki			
	6,501,466 B1	12/2002 Yamagishi			
	6,518,962 B2	2/2003 Kimura			
	6,522,315 B2	2/2003 Ozawa			
	6,525,683 B1	2/2003 Gu			

(56)

References Cited

U.S. PATENT DOCUMENTS

7,119,493 B2	10/2006	Fryer	2002/0011796 A1	1/2002	Koyama
7,122,835 B1	10/2006	Ikeda	2002/0011799 A1	1/2002	Kimura
7,127,380 B1	10/2006	Iverson	2002/0012057 A1	1/2002	Kimura
7,129,914 B2	10/2006	Knapp	2002/0014851 A1	2/2002	Tai
7,161,566 B2	1/2007	Cok	2002/0018034 A1	2/2002	Ohki
7,164,417 B2	1/2007	Cok	2002/0030190 A1	3/2002	Ohtani
7,193,589 B2	3/2007	Yoshida	2002/0047565 A1	4/2002	Nara
7,224,332 B2	5/2007	Cok	2002/0052086 A1	5/2002	Maeda
7,227,519 B1	6/2007	Kawase	2002/0067134 A1	6/2002	Kawashima
7,245,277 B2	7/2007	Ishizuka	2002/0084463 A1	7/2002	Sanford
7,248,236 B2	7/2007	Nathan	2002/0101172 A1	8/2002	Bu
7,262,753 B2	8/2007	Tanghe	2002/0105279 A1	8/2002	Kimura
7,274,363 B2	9/2007	Ishizuka	2002/0117722 A1	8/2002	Osada
7,310,092 B2	12/2007	Imamura	2002/0122308 A1	9/2002	Ikeda
7,315,295 B2	1/2008	Kimura	2002/0158587 A1	10/2002	Komiya
7,321,348 B2	1/2008	Cok	2002/0158666 A1	10/2002	Azami
7,339,560 B2	3/2008	Sun	2002/0158823 A1	10/2002	Zavracky
7,355,574 B1	4/2008	Leon	2002/0167471 A1	11/2002	Everitt
7,358,941 B2	4/2008	Ono	2002/0167474 A1	11/2002	Everitt
7,368,868 B2	5/2008	Sakamoto	2002/0180369 A1	12/2002	Koyama
7,397,485 B2	7/2008	Miller	2002/0180721 A1	12/2002	Kimura
7,411,571 B2	8/2008	Huh	2002/0181276 A1	12/2002	Yamazaki
7,414,600 B2	8/2008	Nathan	2002/0186214 A1	12/2002	Siwinski
7,423,617 B2	9/2008	Giraldo	2002/0190924 A1	12/2002	Asano
7,453,054 B2	11/2008	Lee	2002/0190971 A1	12/2002	Nakamura
7,474,285 B2	1/2009	Kimura	2002/0195967 A1	12/2002	Kim
7,502,000 B2	3/2009	Yuki	2002/0195968 A1	12/2002	Sanford
7,528,812 B2	5/2009	Tsuge	2003/0020413 A1	1/2003	Oomura
7,535,449 B2	5/2009	Miyazawa	2003/0030603 A1	2/2003	Shimoda
7,554,512 B2	6/2009	Steer	2003/0043088 A1	3/2003	Booth
7,569,849 B2	8/2009	Nathan	2003/0057895 A1	3/2003	Kimura
7,576,718 B2	8/2009	Miyazawa	2003/0058226 A1	3/2003	Bertram
7,580,012 B2	8/2009	Kim	2003/0062524 A1	4/2003	Kimura
7,589,707 B2	9/2009	Chou	2003/0063081 A1	4/2003	Kimura
7,609,239 B2	10/2009	Chang	2003/0071821 A1	4/2003	Sundahl
7,619,594 B2	11/2009	Hu	2003/0076048 A1	4/2003	Rutherford
7,619,597 B2	11/2009	Nathan	2003/0090447 A1	5/2003	Kimura
7,633,470 B2	12/2009	Kane	2003/0090481 A1	5/2003	Kimura
7,656,370 B2	2/2010	Schneider	2003/0107560 A1	6/2003	Yumoto
7,800,558 B2	9/2010	Routley	2003/0111966 A1	6/2003	Mikami
7,847,764 B2	12/2010	Cok	2003/0122745 A1	7/2003	Miyazawa
7,859,492 B2	12/2010	Kohno	2003/0122813 A1	7/2003	Ishizuki
7,868,859 B2	1/2011	Tomida	2003/0142088 A1	7/2003	LeChevalier
7,876,294 B2	1/2011	Sasaki	2003/0151569 A1	8/2003	Lee
7,924,249 B2	4/2011	Nathan	2003/0156101 A1	8/2003	Le Chevalier
7,932,883 B2	4/2011	Klompenhouwer	2003/0174152 A1	9/2003	Noguchi
7,969,390 B2	6/2011	Yoshida	2003/0179626 A1	9/2003	Sanford
7,978,187 B2	7/2011	Nathan	2003/0185438 A1	10/2003	Osawa
7,994,712 B2	8/2011	Sung	2003/0197663 A1	10/2003	Lee
8,026,876 B2	9/2011	Nathan	2003/0210256 A1	11/2003	Mori
8,049,420 B2	11/2011	Tamura	2003/0230141 A1	12/2003	Gilmour
8,077,123 B2	12/2011	Naugler, Jr.	2003/0230980 A1	12/2003	Forrest
8,115,707 B2	2/2012	Nathan	2003/0231148 A1	12/2003	Lin
8,208,084 B2	6/2012	Lin	2004/0032382 A1	2/2004	Cok
8,223,177 B2	7/2012	Nathan	2004/0041750 A1	3/2004	Abe
8,232,939 B2	7/2012	Nathan	2004/0066357 A1	4/2004	Kawasaki
8,259,044 B2	9/2012	Nathan	2004/0070557 A1	4/2004	Asano
8,264,431 B2	9/2012	Bulovic	2004/0070565 A1	4/2004	Nayar
8,279,143 B2	10/2012	Nathan	2004/0090186 A1	5/2004	Kanauchi
8,339,386 B2	12/2012	Leon	2004/0090400 A1	5/2004	Yoo
8,441,206 B2	5/2013	Myers	2004/0095297 A1	5/2004	Libsch
8,493,296 B2	7/2013	Ogawa	2004/0100427 A1	5/2004	Miyazawa
2001/0002703 A1	6/2001	Koyama	2004/0108518 A1	6/2004	Jo
2001/0009283 A1	7/2001	Arao	2004/0135749 A1	7/2004	Kondakov
2001/0024181 A1	9/2001	Kubota	2004/0140982 A1	7/2004	Pate
2001/0024186 A1	9/2001	Kane	2004/0145547 A1	7/2004	Oh
2001/0026257 A1	10/2001	Kimura	2004/0150592 A1	8/2004	Mizukoshi
2001/0030323 A1	10/2001	Ikeda	2004/0150594 A1	8/2004	Koyama
2001/0035863 A1	11/2001	Kimura	2004/0150595 A1	8/2004	Kasai
2001/0040541 A1	11/2001	Yoneda	2004/0155841 A1	8/2004	Kasai
2001/0043173 A1	11/2001	Troutman	2004/0174347 A1	9/2004	Sun
2001/0045929 A1	11/2001	Prache	2004/0174349 A1	9/2004	Libsch
2001/0052606 A1	12/2001	Sempel	2004/0174354 A1	9/2004	Ono
2001/0052940 A1	12/2001	Hagihara	2004/0178743 A1	9/2004	Miller
2002/0000576 A1	1/2002	Inukai	2004/0183759 A1	9/2004	Stevenson
			2004/0196275 A1	10/2004	Hattori
			2004/0207615 A1	10/2004	Yumoto
			2004/0227697 A1	11/2004	Mori
			2004/0233125 A1	11/2004	Tanghe

(56)

References Cited

U.S. PATENT DOCUMENTS

2004/0239596	A1	12/2004	Ono	2006/0244697	A1	11/2006	Lee
2004/0252089	A1	12/2004	Ono	2006/0261841	A1	11/2006	Fish
2004/0257313	A1	12/2004	Kawashima	2006/0273997	A1	12/2006	Nathan
2004/0257353	A1	12/2004	Imamura	2006/0279481	A1	12/2006	Haruna
2004/0257355	A1	12/2004	Naugler	2006/0284801	A1	12/2006	Yoon
2004/0263437	A1	12/2004	Hattori	2006/0284802	A1	12/2006	Kohno
2004/0263444	A1	12/2004	Kimura	2006/0284895	A1	12/2006	Marcu
2004/0263445	A1	12/2004	Inukai	2006/0290618	A1	12/2006	Goto
2004/0263541	A1	12/2004	Takeuchi	2007/0001937	A1	1/2007	Park
2005/0007355	A1	1/2005	Miura	2007/0001939	A1	1/2007	Hashimoto
2005/0007357	A1	1/2005	Yamashita	2007/0008251	A1	1/2007	Kohno
2005/0007392	A1	1/2005	Kasai	2007/0008268	A1	1/2007	Park
2005/0017650	A1	1/2005	Fryer	2007/0008297	A1	1/2007	Bassetti
2005/0024081	A1	2/2005	Kuo	2007/0057873	A1	3/2007	Uchino
2005/0024393	A1	2/2005	Kondo	2007/0057874	A1	3/2007	Le Roy
2005/0030267	A1	2/2005	Tanghe	2007/0069998	A1	3/2007	Naugler
2005/0057484	A1	3/2005	Diefenbaugh	2007/0075727	A1	4/2007	Nakano
2005/0057580	A1	3/2005	Yamano	2007/0076226	A1	4/2007	Klompenuhouwer
2005/0067970	A1	3/2005	Libsch	2007/0080905	A1	4/2007	Takahara
2005/0067971	A1	3/2005	Kane	2007/0080906	A1	4/2007	Tanabe
2005/0068270	A1	3/2005	Awakura	2007/0080908	A1	4/2007	Nathan
2005/0068275	A1	3/2005	Kane	2007/0097038	A1	5/2007	Yamazaki
2005/0073264	A1	4/2005	Matsumoto	2007/0097041	A1	5/2007	Park
2005/0083323	A1	4/2005	Suzuki	2007/0103411	A1	5/2007	Cok et al.
2005/0088103	A1	4/2005	Kageyama	2007/0103419	A1	5/2007	Uchino
2005/0110420	A1	5/2005	Arnold	2007/0115221	A1	5/2007	Buchhauser
2005/0110807	A1	5/2005	Chang	2007/0126672	A1	6/2007	Tada et al.
2005/0122294	A1	6/2005	Ben-David	2007/0164664	A1	7/2007	Ludwicki
2005/0140598	A1	6/2005	Kim	2007/0182671	A1	8/2007	Nathan
2005/0140610	A1	6/2005	Smith	2007/0236134	A1	10/2007	Ho
2005/0145891	A1	7/2005	Abe	2007/0236440	A1	10/2007	Wacyk
2005/0156831	A1	7/2005	Yamazaki	2007/0236517	A1	10/2007	Kimpe
2005/0162079	A1	7/2005	Sakamoto	2007/0241999	A1	10/2007	Lin
2005/0168416	A1	8/2005	Hashimoto	2007/0273294	A1	11/2007	Nagayama
2005/0179626	A1	8/2005	Yuki	2007/0285359	A1	12/2007	Ono
2005/0179628	A1	8/2005	Kimura	2007/0290957	A1	12/2007	Cok
2005/0185200	A1	8/2005	Tobol	2007/0290958	A1	12/2007	Cok
2005/0200575	A1	9/2005	Kim	2007/0296672	A1	12/2007	Kim
2005/0206590	A1	9/2005	Sasaki	2008/0001525	A1	1/2008	Chao
2005/0212787	A1	9/2005	Noguchi	2008/0001544	A1	1/2008	Murakami
2005/0219184	A1	10/2005	Zehner	2008/0030518	A1	2/2008	Higgins
2005/0225683	A1	10/2005	Nozawa	2008/0036706	A1	2/2008	Kitazawa
2005/0248515	A1	11/2005	Naugler	2008/0036708	A1	2/2008	Shirasaki
2005/0269959	A1	12/2005	Uchino	2008/0042942	A1	2/2008	Takahashi
2005/0269960	A1	12/2005	Ono	2008/0042948	A1	2/2008	Yamashita
2005/0280615	A1	12/2005	Cok	2008/0048951	A1	2/2008	Naugler, Jr.
2005/0280766	A1	12/2005	Johnson	2008/0055209	A1	3/2008	Cok
2005/0285822	A1	12/2005	Reddy	2008/0055211	A1	3/2008	Ogawa
2005/0285825	A1	12/2005	Eom	2008/0074413	A1	3/2008	Ogura
2006/0001613	A1	1/2006	Routley	2008/0088549	A1	4/2008	Nathan
2006/0007072	A1	1/2006	Choi	2008/0088648	A1	4/2008	Nathan
2006/0007249	A1	1/2006	Reddy	2008/0111766	A1	5/2008	Uchino
2006/0012310	A1	1/2006	Chen	2008/0116787	A1	5/2008	Hsu
2006/0012311	A1	1/2006	Ogawa	2008/0117144	A1	5/2008	Nakano et al.
2006/0022305	A1	2/2006	Yamashita	2008/0136770	A1	6/2008	Peker
2006/0027807	A1	2/2006	Nathan	2008/0150845	A1	6/2008	Ishii
2006/0030084	A1	2/2006	Young	2008/0150847	A1	6/2008	Kim
2006/0038758	A1	2/2006	Routley	2008/0158115	A1	7/2008	Cordes
2006/0038762	A1	2/2006	Chou	2008/0158648	A1	7/2008	Cummings
2006/0044227	A1	3/2006	Hadcock	2008/0191976	A1	8/2008	Nathan
2006/0066533	A1	3/2006	Sato	2008/0198103	A1	8/2008	Toyomura
2006/0077135	A1	4/2006	Cok	2008/0211749	A1	9/2008	Weitbruch
2006/0077142	A1	4/2006	Kwon	2008/0231558	A1	9/2008	Naugler
2006/0082523	A1	4/2006	Guo	2008/0231562	A1	9/2008	Kwon
2006/0092185	A1	5/2006	Jo	2008/0231625	A1	9/2008	Minami
2006/0097628	A1	5/2006	Suh	2008/0252223	A1	10/2008	Toyoda
2006/0097631	A1	5/2006	Lee	2008/0252571	A1	10/2008	Hente
2006/0103611	A1	5/2006	Choi	2008/0259020	A1	10/2008	Fisekovic
2006/0149493	A1	7/2006	Sambandan	2008/0290805	A1	11/2008	Yamada
2006/0170623	A1	8/2006	Naugler, Jr.	2008/0297055	A1	12/2008	Miyake
2006/0176250	A1	8/2006	Nathan	2009/0058772	A1	3/2009	Lee
2006/0208961	A1	9/2006	Nathan	2009/0109142	A1	4/2009	Takahara
2006/0208971	A1	9/2006	Deane	2009/0121994	A1	5/2009	Miyata
2006/0214888	A1	9/2006	Schneider	2009/0146926	A1	6/2009	Sung
2006/0232522	A1	10/2006	Roy	2009/0160743	A1	6/2009	Tomida
				2009/0174628	A1	7/2009	Wang
				2009/0184901	A1	7/2009	Kwon
				2009/0195483	A1	8/2009	Naugler, Jr.
				2009/0201281	A1	8/2009	Routley

(56)

References Cited

U.S. PATENT DOCUMENTS

2009/0206764 A1 8/2009 Schemmann
 2009/0213046 A1 8/2009 Nam
 2009/0244046 A1 10/2009 Seto
 2009/0262047 A1 10/2009 Yamashita
 2010/0004891 A1 1/2010 Ahlers
 2010/0026725 A1 2/2010 Smith
 2010/0039422 A1 2/2010 Seto
 2010/0039458 A1 2/2010 Nathan
 2010/0060911 A1 3/2010 Marcu
 2010/0079419 A1 4/2010 Shibusawa
 2010/0165002 A1 7/2010 Ahn
 2010/0194670 A1 8/2010 Cok
 2010/0207960 A1 8/2010 Kimpe
 2010/0225630 A1 9/2010 Levey
 2010/0251295 A1 9/2010 Amento
 2010/0277400 A1 11/2010 Jeong
 2010/0315319 A1 12/2010 Cok
 2010/0315449 A1* 12/2010 Chaji G09G 3/3208
 345/690
 2011/0063197 A1 3/2011 Chung
 2011/0069051 A1 3/2011 Nakamura
 2011/0069089 A1 3/2011 Kopf
 2011/0069094 A1* 3/2011 Knapp G09G 3/2003
 345/690
 2011/0074750 A1 3/2011 Leon
 2011/0149166 A1 6/2011 Botzas
 2011/0169798 A1 7/2011 Lee
 2011/0181630 A1 7/2011 Smith
 2011/0199395 A1 8/2011 Nathan
 2011/0227964 A1 9/2011 Chaji
 2011/0242074 A1 10/2011 Bert
 2011/0273399 A1 11/2011 Lee
 2011/0293480 A1 12/2011 Mueller
 2012/0056558 A1 3/2012 Toshiya
 2012/0062565 A1 3/2012 Fuchs
 2012/0262184 A1 10/2012 Shen
 2012/0299970 A1 11/2012 Bae
 2012/0299978 A1 11/2012 Chaji
 2013/0027381 A1 1/2013 Nathan
 2013/0057595 A1 3/2013 Nathan
 2013/0112960 A1 5/2013 Chaji
 2013/0135272 A1 5/2013 Park
 2013/0162617 A1 6/2013 Yoon
 2013/0201223 A1 8/2013 Li et al.
 2013/0309821 A1 11/2013 Yoo
 2013/0321671 A1 12/2013 Cote
 2014/0111567 A1 4/2014 Nathan et al.

FOREIGN PATENT DOCUMENTS

CA 2 249 592 7/1998
 CA 2 368 386 9/1999
 CA 2 242 720 1/2000
 CA 2 354 018 6/2000
 CA 2 432 530 7/2002
 CA 2 436 451 8/2002
 CA 2 438 577 8/2002
 CA 2 463 653 1/2004
 CA 2 498 136 3/2004
 CA 2 522 396 11/2004
 CA 2 443 206 3/2005
 CA 2 472 671 12/2005
 CA 2 567 076 1/2006
 CA 2 526 782 4/2006
 CA 2 541 531 7/2006
 CA 2 550 102 4/2008
 CA 2 773 699 10/2013
 CN 1381032 11/2002
 CN 1448908 10/2003
 CN 1682267 A 10/2005
 CN 1760945 4/2006
 CN 1886774 12/2006
 CN 102656621 9/2012
 EP 0 158 366 10/1985

EP 1 028 471 8/2000
 EP 1 111 577 6/2001
 EP 1 130 565 A1 9/2001
 EP 1 194 013 4/2002
 EP 1 335 430 A1 8/2003
 EP 1 372 136 12/2003
 EP 1 381 019 1/2004
 EP 1 418 566 5/2004
 EP 1 429 312 A 6/2004
 EP 145 0341 A 8/2004
 EP 1 465 143 A 10/2004
 EP 1 469 448 A 10/2004
 EP 1 521 203 A2 4/2005
 EP 1 594 347 11/2005
 EP 1 784 055 A2 5/2007
 EP 1854338 A1 11/2007
 EP 1 879 169 A1 1/2008
 EP 1 879 172 1/2008
 EP 2395499 A1 12/2011
 GB 2 389 951 12/2003
 JP 1272298 10/1989
 JP 4-042619 2/1992
 JP 6-314977 11/1994
 JP 8-340243 12/1996
 JP 09-090405 4/1997
 JP 10-254410 9/1998
 JP 11-202295 7/1999
 JP 11-219146 8/1999
 JP 11 231805 8/1999
 JP 11-282419 10/1999
 JP 2000-056847 2/2000
 JP 2000-81607 3/2000
 JP 2001-134217 5/2001
 JP 2001-195014 7/2001
 JP 2002-055654 2/2002
 JP 2002-91376 3/2002
 JP 2002-514320 5/2002
 JP 2002-278513 9/2002
 JP 2002-333862 11/2002
 JP 2003-076331 3/2003
 JP 2003-124519 4/2003
 JP 2003-177709 6/2003
 JP 2003-271095 9/2003
 JP 2003-308046 10/2003
 JP 2003-317944 11/2003
 JP 2004-004675 1/2004
 JP 2004-145197 5/2004
 JP 2004-287345 10/2004
 JP 2005-057217 3/2005
 JP 2007-065015 3/2007
 JP 2008-102335 5/2008
 JP 4-158570 10/2008
 KR 2004-0100887 12/2004
 TW 342486 10/1998
 TW 473622 1/2002
 TW 485337 5/2002
 TW 502233 9/2002
 TW 538650 6/2003
 TW 1221268 9/2004
 TW 1223092 11/2004
 TW 200727247 7/2007
 WO 98/48403 10/1998
 WO 99/48079 9/1999
 WO 01/06484 1/2001
 WO 01/27910 A1 4/2001
 WO 01/63587 A2 8/2001
 WO 02/067327 A 8/2002
 WO 03/001496 A1 1/2003
 WO 03/034389 A 4/2003
 WO 03/058594 A1 7/2003
 WO 03/063124 7/2003
 WO 03/077231 9/2003
 WO WO 2004/003877 1/2004
 WO WO 2004/025615 A 3/2004
 WO WO 2004/034364 4/2004
 WO WO 2004/047058 6/2004
 WO WO 2004/104975 A1 12/2004
 WO WO 2005/022498 3/2005
 WO WO 2005/022500 A 3/2005

(56) **References Cited**

FOREIGN PATENT DOCUMENTS

WO	WO 2005/029455	3/2005
WO	WO 2005/029456	3/2005
WO	WO 2005/055185	6/2005
WO	WO 2006/000101 A1	1/2006
WO	WO 2006/053424	5/2006
WO	WO 2006/063448 A	6/2006
WO	WO 2006/084360	8/2006
WO	WO 2007/003877 A	1/2007
WO	WO 2007/079572	7/2007
WO	WO 2007/120849 A2	10/2007
WO	WO 2009/048618	4/2009
WO	WO 2009/055920	5/2009
WO	WO 2010/023270	3/2010
WO	WO 2010/146707 A1	12/2010
WO	WO 2011/041224 A1	4/2011
WO	WO 2011/064761 A1	6/2011
WO	WO 2011/067729	6/2011
WO	WO 2012/160424 A1	11/2012
WO	WO 2012/160471	11/2012
WO	WO 2012/164474 A2	12/2012
WO	WO 2012/164475 A2	12/2012

OTHER PUBLICATIONS

Alexander : "Pixel circuits and drive schemes for glass and elastic AMOLED displays"; dated Jul. 2005 (9 pages).

Alexander : "Unique Electrical Measurement Technology for Compensation, Inspection, and Process Diagnostics of AMOLED HDTV"; dated May 2010 (4 pages).

Ashtiani : "AMOLED Pixel Circuit With Electronic Compensation of Luminance Degradation"; dated Mar. 2007 (4 pages).

Chaji : "A Current-Mode Comparator for Digital Calibration of Amorphous Silicon AMOLED Displays"; dated Jul. 2008 (5 pages).

Chaji : "A fast settling current driver based on the CCII for AMOLED displays"; dated Dec. 2009 (6 pages).

Chaji : "A Low-Cost Stable Amorphous Silicon AMOLED Display with Full V~T- and V~O~L~E~D Shift Compensation"; dated May 2007 (4 pages).

Chaji : "A low-power driving scheme for a-Si:H active-matrix organic light-emitting diode displays"; dated Jun. 2005 (4 pages).

Chaji : "A low-power high-performance digital circuit for deep submicron technologies"; dated Jun. 2005 (4 pages).

Chaji : "A novel a-Si:H AMOLED pixel circuit based on short-term stress stability of a-Si:H TFTs"; dated Oct. 2005 (3 pages).

Chaji : "A Novel Driving Scheme and Pixel Circuit for AMOLED Displays"; dated Jun. 2006 (4 pages).

Chaji : "A Novel Driving Scheme for High Resolution Large-area a-Si:H AMOLED displays"; dated Aug. 2005 (3 pages).

Chaji : "A Stable Voltage-Programmed Pixel Circuit for a-Si:H AMOLED Displays"; dated Dec. 2006 (12 pages).

Chaji : "A Sub- μ A fast-settling current-programmed pixel circuit for AMOLED displays"; dated Sep. 2007.

Chaji : "An Enhanced and Simplified Optical Feedback Pixel Circuit for AMOLED Displays"; dated Oct. 2006.

Chaji : "Compensation technique for DC and transient instability of thin film transistor circuits for large-area devices"; dated Aug. 2008.

Chaji : "Driving scheme for stable operation of 2-TFT a-Si AMOLED pixel"; dated Apr. 2005 (2 pages).

Chaji : "Dynamic-effect compensating technique for stable a-Si:H AMOLED displays"; dated Aug. 2005 (4 pages).

Chaji : "Electrical Compensation of OLED Luminance Degradation"; dated Dec. 2007 (3 pages).

Chaji : "eUTDSP: a design study of a new VLIW-based DSP architecture"; dated My 2003 (4 pages).

Chaji : "Fast and Offset-Leakage Insensitive Current-Mode Line Driver for Active Matrix Displays and Sensors"; dated Feb. 2009 (8 pages).

Chaji : "High Speed Low Power Adder Design With a New Logic Style: Pseudo Dynamic Logic (SDL)"; dated Oct. 2001 (4 pages).

Chaji : "High-precision, fast current source for large-area current-programmed a-Si flat panels"; dated Sep. 2006 (4 pages).

Chaji : "Low-Cost AMOLED Television with IGNIS Compensating Technology"; dated May 2008 (4 pages).

Chaji : "Low-Cost Stable a-Si:H AMOLED Display for Portable Applications"; dated Jun. 2006 (4 pages).

Chaji : "Low-Power Low-Cost Voltage-Programmed a-Si:H AMOLED Display"; dated Jun. 2008 (5 pages).

Chaji : "Merged phototransistor pixel with enhanced near infrared response and flicker noise reduction for biomolecular imaging"; dated Nov. 2008 (3 pages).

Chaji : "Parallel Addressing Scheme for Voltage-Programmed Active-Matrix OLED Displays"; dated May 2007 (6 pages).

Chaji : "Pseudo dynamic logic (SDL): a high-speed and low-power dynamic logic family"; dated 2002 (4 pages).

Chaji : "Stable a-Si:H circuits based on short-term stress stability of amorphous silicon thin film transistors"; dated May 2006 (4 pages).

Chaji : "Stable Pixel Circuit for Small-Area High-Resolution a-Si:H AMOLED Displays"; dated Oct. 2008 (6 pages).

Chaji : "Stable RGBW AMOLED display with OLED degradation compensation using electrical feedback"; dated Feb. 2010 (2 pages).

Chaji : "Thin-Film Transistor Integration for Biomedical Imaging and AMOLED Displays"; dated 2008 (177 pages).

European Search Report for Application No. EP 01 11 22313 dated Sep. 14, 2005 (4 pages).

European Search Report for Application No. EP 04 78 6661 dated Mar. 9, 2009.

European Search Report for Application No. EP 05 75 9141 dated Oct. 30, 2009. (2 pages).

European Search Report for Application No. EP 05 81 9617 dated Jan. 30, 2009.

European Search Report for Application No. EP 06 70 5133 dated Jul. 18, 2008.

European Search Report for Application No. EP 06 72 1798 dated Nov. 12, 2009 (2 pages).

European Search Report for Application No. EP 07 71 0608.6 dated Mar. 19, 2010 (7 pages).

European Search Report for Application No. EP 07 71 9579 dated May 20, 2009.

European Search Report for Application No. EP 07 81 5784 dated Jul. 20, 2010 (2 pages).

European Search Report for Application No. EP 10 16 6143, dated Sep. 3, 2010 (2 pages).

European Search Report for Application No. EP 10 83 4294.0-1903, dated Apr. 8, 2013, (9 pages).

European Search Report for Application No. PCT/CA2006/000177 dated Jun. 2, 2006.

European Supplementary Search Report for Application No. EP 04 78 6662 dated Jan. 19, 2007 (2 pages).

Extended European Search Report for Application No. 11 73 9485.8 mailed Aug. 6, 2013(14 pages).

Extended European Search Report for Application No. EP 09 73 3076.5, mailed Apr. 27, (13 pages).

Extended European Search Report for Application No. EP 11 16 8677.0, mailed Nov. 29, 2012, (13 page).

Extended European Search Report for Application No. EP 11 19 1641.7 mailed Jul. 11, 2012 (14 pages).

Extended European Search Report for Application No. EP 10834297 mailed Oct. 27, 2014 (6 pages).

Fossum, Eric R.. "Active Pixel Sensors: Are CCD's Dinosaurs?" SPIE: Symposium on Electronic Imaging, Feb. 1, 1993 (13 pages).

Goh , "A New a-Si:H Thin-Film Transistor Pixel Circuit for Active-Matrix Organic Light-Emitting Diodes", IEEE Electron Device Letters, vol. 24, No. 9, Sep. 2003, pp. 583-585.

International Preliminary Report on Patentability for Application No. PCT/CA2005/001007 dated Oct. 16, 2006, 4 pages.

International Search Report for Application No. PCT/CA2004/001741 dated Feb. 21, 2005.

International Search Report for Application No. PCT/CA2004/001742, Canadian Patent Office, dated Feb. 21, 2005 (2 pages).

International Search Report for Application No. PCT/CA2005/001007 dated Oct. 18, 2005.

(56)

References Cited

OTHER PUBLICATIONS

- International Search Report for Application No. PCT/CA2005/001897, mailed Mar. 21, 2006 (2 pages).
- International Search Report for Application No. PCT/CA2007/000652 dated Jul. 25, 2007.
- International Search Report for Application No. PCT/CA2009/000501, mailed Jul. 30, 2009 (4 pages).
- International Search Report for Application No. PCT/CA2009/001769, dated Apr. 8, 2010 (3 pages).
- International Search Report for Application No. PCT/IB2010/055481, dated Apr. 7, 2011, 3 pages.
- International Search Report for Application No. PCT/IB2010/055486, Dated Apr. 19, 2011, 5 pages.
- International Search Report for Application No. PCT/IB2014/060959, Dated Aug. 28, 2014, 5 pages.
- International Search Report for Application No. PCT/IB2010/055541 filed Dec. 1, 2010, dated May 26, 2011; 5 pages.
- International Search Report for Application No. PCT/IB2011/050502, dated Jun. 27, 2011 (6 pages).
- International Search Report for Application No. PCT/IB2011/051103, dated Jul. 8, 2011, 3 pages.
- International Search Report for Application No. PCT/IB2011/055135, Canadian Patent Office, dated Apr. 16, 2012 (5 pages).
- International Search Report for Application No. PCT/IB2012/052372, mailed Sep. 12, 2012 (3 pages).
- International Search Report for Application No. PCT/IB2013/054251, Canadian Intellectual Property Office, dated Sep. 11, 2013; (4 pages).
- International Search Report for Application No. PCT/JP02/09668, mailed Dec. 3, 2002, (4 pages).
- International Written Opinion for Application No. PCT/CA2004/001742, Canadian Patent Office, dated Feb. 21, 2005 (5 pages).
- International Written Opinion for Application No. PCT/CA2005/001897, mailed Mar. 21, 2006 (4 pages).
- International Written Opinion for Application No. PCT/CA2009/000501 mailed Jul. 30, 2009 (6 pages).
- International Written Opinion for Application No. PCT/IB2010/055481, dated Apr. 7, 2011, 6 pages.
- International Written Opinion for Application No. PCT/IB2010/055486, Dated Apr. 19, 2011, 8 pages.
- International Written Opinion for Application No. PCT/IB2010/055541, dated May 26, 2011; 6 pages.
- International Written Opinion for Application No. PCT/IB2011/050502, dated Jun. 27, 2011 (7 pages).
- International Written Opinion for Application No. PCT/IB2011/051103, dated Jul. 8, 2011, 6 pages.
- International Written Opinion for Application No. PCT/IB2011/055135, Canadian Patent Office, dated Apr. 16, 2012 (5 pages).
- International Written Opinion for Application No. PCT/IB2012/052372, mailed Sep. 12, 2012 (6 pages).
- International Written Opinion for Application No. PCT/IB2013/054251, Canadian Intellectual Property Office, dated Sep. 11, 2013; (5 pages).
- International Written Opinion for Application No. PCT/IB2014/060879, Canadian Intellectual Property Office, dated Jul. 17, 2014; (4 pages).
- Jafarabadiastiani : "A New Driving Method for a-Si AMOLED Displays Based on Voltage Feedback"; dated 2005 (4 pages).
- Kanicki, J., "Amorphous Silicon Thin-Film Transistors Based Active-Matrix Organic Light-Emitting Displays." Asia Display: International Display Workshops, Sep. 2001 (pp. 315-318).
- Karim, K. S., "Amorphous Silicon Active Pixel Sensor Readout Circuit for Digital Imaging." IEEE: Transactions on Electron Devices. vol. 50, No. 1, Jan. 2003 (pp. 200-208).
- Lee : "Ambipolar Thin-Film Transistors Fabricated by PECVD Nanocrystalline Silicon"; dated 2006.
- Lee, Wonbok: "Thermal Management in Microprocessor Chips and Dynamic Backlight Control in Liquid Crystal Displays", Ph.D. Dissertation, University of Southern California (124 pages).
- Liu, P. et al., Innovative Voltage Driving Pixel Circuit Using Organic Thin-Film Transistor for AMOLEDs, Journal of Display Technology, vol. 5, Issue 6, Jun. 2009 (pp. 224-227).
- Ma E Y: "organic light emitting diode/thin film transistor integration for foldable displays" dated Sep. 15, 1997(4 pages).
- Matsueda y : "35.1: 2.5-in. AMOLED with Integrated 6-bit Gamma Compensated Digital Data Driver"; dated May 2004.
- Mendes E., "A High Resolution Switch-Current Memory Base Cell." IEEE: Circuits and Systems. vol. 2, Aug. 1999 (pp. 718-721).
- Nathan A. , "Thin Film imaging technology on glass and plastic" ICM 2000, proceedings of the 12 international conference on microelectronics, dated Oct. 31, 2001 (4 pages).
- Nathan , "Amorphous Silicon Thin Film Transistor Circuit Integration for Organic LED Displays on Glass and Plastic", IEEE Journal of Solid-State Circuits, vol. 39, No. 9, Sep. 2004, pp. 1477-1486.
- Nathan : "Backplane Requirements for active Matrix Organic Light Emitting Diode Displays,"; dated 2006 (16 pages).
- Nathan : "Call for papers second international workshop on compact thin-film transistor (TFT) modeling for circuit simulation"; dated Sep. 2009 (1 page).
- Nathan : "Driving schemes for a-Si and LTPS AMOLED displays"; dated Dec. 2005 (11 pages).
- Nathan : "Invited Paper: a-Si for AMOLED—Meeting the Performance and Cost Demands of Display Applications (Cell Phone to HDTV)"; dated 2006 (4 pages).
- Office Action in Japanese patent application No. JP2006-527247 dated Mar. 15, 2010. (8 pages).
- Office Action in Japanese patent application no. JP2007-545796 dated Sep. 5, 2011. (8 pages).
- Office Action in Japanese patent application No. JP2012-541612 dated Jul. 15, 2014. (3 pages).
- Partial European Search Report for Application No. EP 11 168 677.0, mailed Sep. 22, 2011 (5 pages).
- Partial European Search Report for Application No. EP 11 19 1641.7, mailed Mar. 20, 2012 (8 pages).
- Philipp: "Charge transfer sensing" Sensor Review, vol. 19, No. 2, Dec. 31, 1999 (Dec. 31, 1999), 10 pages.
- Rafati : "Comparison of a 17 b multiplier in Dual-rail domino and in Dual-rail D L (D L) logic styles"; dated 2002 (4 pages).
- Safavian : "3-TFT active pixel sensor with correlated double sampling readout circuit for real-time medical x-ray imaging"; dated Jun. 2006 (4 pages).
- Safavian : "A novel current scaling active pixel sensor with correlated double sampling readout circuit for real time medical x-ray imaging"; dated May 2007 (7 pages).
- Safavian : "A novel hybrid active-passive pixel with correlated double sampling CMOS readout circuit for medical x-ray imaging"; dated May 2008 (4 pages).
- Safavian : "Self-compensated a-Si:H detector with current-mode readout circuit for digital X-ray fluoroscopy"; dated Aug. 2005 (4 pages).
- Safavian : "TFT active image sensor with current-mode readout circuit for digital x-ray fluoroscopy [5969D-82]"; dated Sep. 2005 (9 pages).
- Safavian : "Three-TFT image sensor for real-time digital X-ray imaging"; dated Feb. 2, 2006 (2 pages).
- Search Report for Taiwan Invention Patent Application No. 093128894 dated May 1, 2012. (1 page).
- Search Report for Taiwan Invention Patent Application No. 94144535 dated Nov. 1, 2012. (1 page).
- Singh., "Current Conveyor: Novel Universal Active Block", Samriddhi, S-JPSET vol. I, Issue 1, 2010, pp. 41-48 (12EPPT).
- Smith, Lindsay I., "A tutorial on Principal Components Analysis," dated Feb. 26, 2001 (27 pages).
- Spindler , System Considerations for RGBW OLED Displays, Journal of the SID 14/1, 2006, pp. 37-48.
- Stewart M. , "polysilicon TFT technology for active matrix oled displays" IEEE transactions on electron devices, vol. 48, No. 5, dated May 2001 (7 pages).
- Vygranenko : "Stability of indium-oxide thin-film transistors by reactive ion beam assisted deposition"; dated 2009.

(56)

References Cited

OTHER PUBLICATIONS

Wang : "Indium oxides by reactive ion beam assisted evaporation: From material study to device application"; dated Mar. 2009 (6 pages).

Yi He , "Current-Source a-Si:H Thin Film Transistor Circuit for Active-Matrix Organic Light-Emitting Displays", IEEE Electron Device Letters, vol. 21, No. 12, Dec. 2000, pp. 590-592.

Yu, Jennifer "Improve OLED Technology for Display", Ph.D. Dissertation, Massachusetts Institute of Technology, Sep. 2008 (151 pages).

International Search Report for Application No. PCT/IB2014/058244, Canadian Intellectual Property Office, dated Apr. 11, 2014; (6 pages).

International Search Report for Application No. PCT/IB2014/059753, Canadian Intellectual Property Office, dated Jun. 23, 2014; (6 pages).

Written Opinion for Application No. PCT/IB2014/059753, Canadian Intellectual Property Office, dated Jun. 12, 2014 (6 pages).

International Search Report for Application No. PCT/IB2014/060879, Canadian Intellectual Property Office, dated Jul. 17, 2014 (3 pages).

Extended European Search Report for Application No. EP 14158051.4, mailed Jul. 29, 2014, (4 pages).

Office Action in Chinese Patent Invention No. 201180008188.9, dated Jun. 4, 2014 (17 pages).

International Search Report for Application No. PCT/IB/2014/066932 dated Mar. 24, 2015.

Written Opinion for Application No. PCT/IB/2014/066932 dated Mar. 24, 2015.

Extended European Search Report for Application No. EP 11866291.5, mailed Mar. 9, 2015, (9 pages).

Extended European Search Report for Application No. EP 14181848.4, mailed Mar. 5, 2015, (8 pages).

* cited by examiner

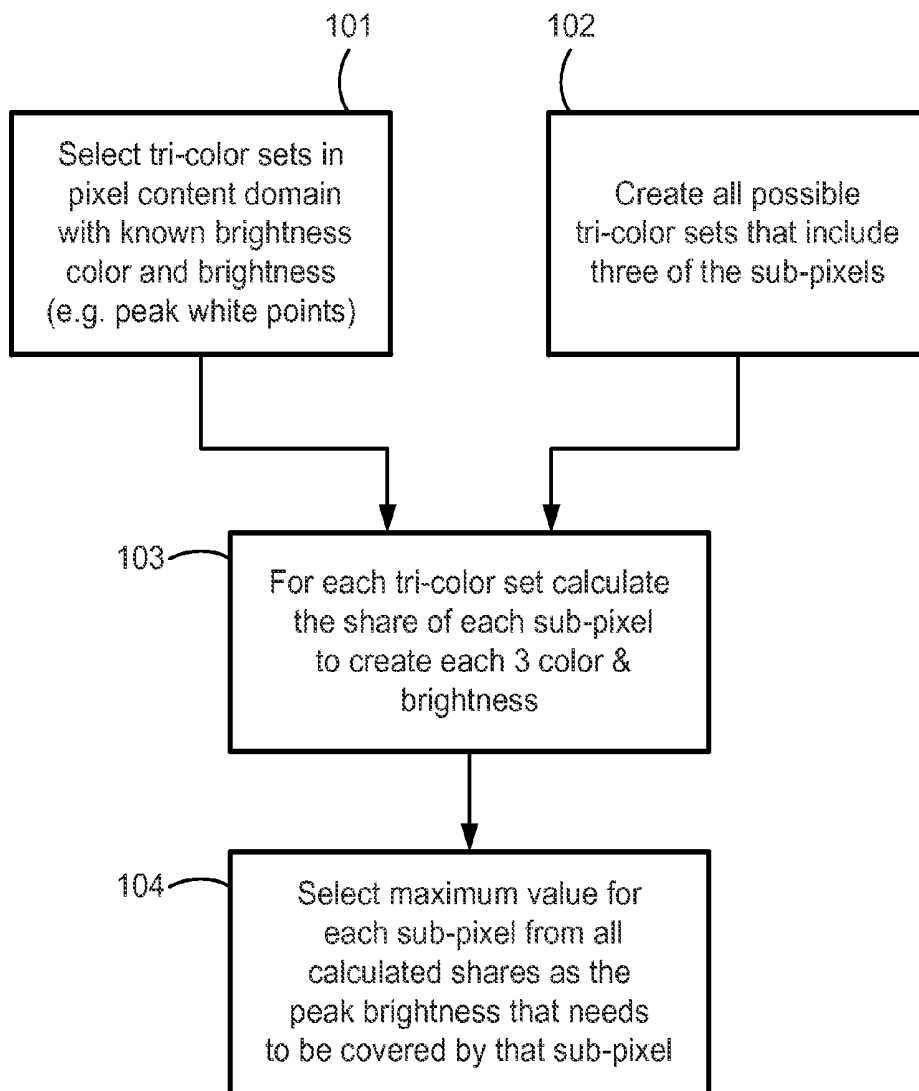

FIG. 1

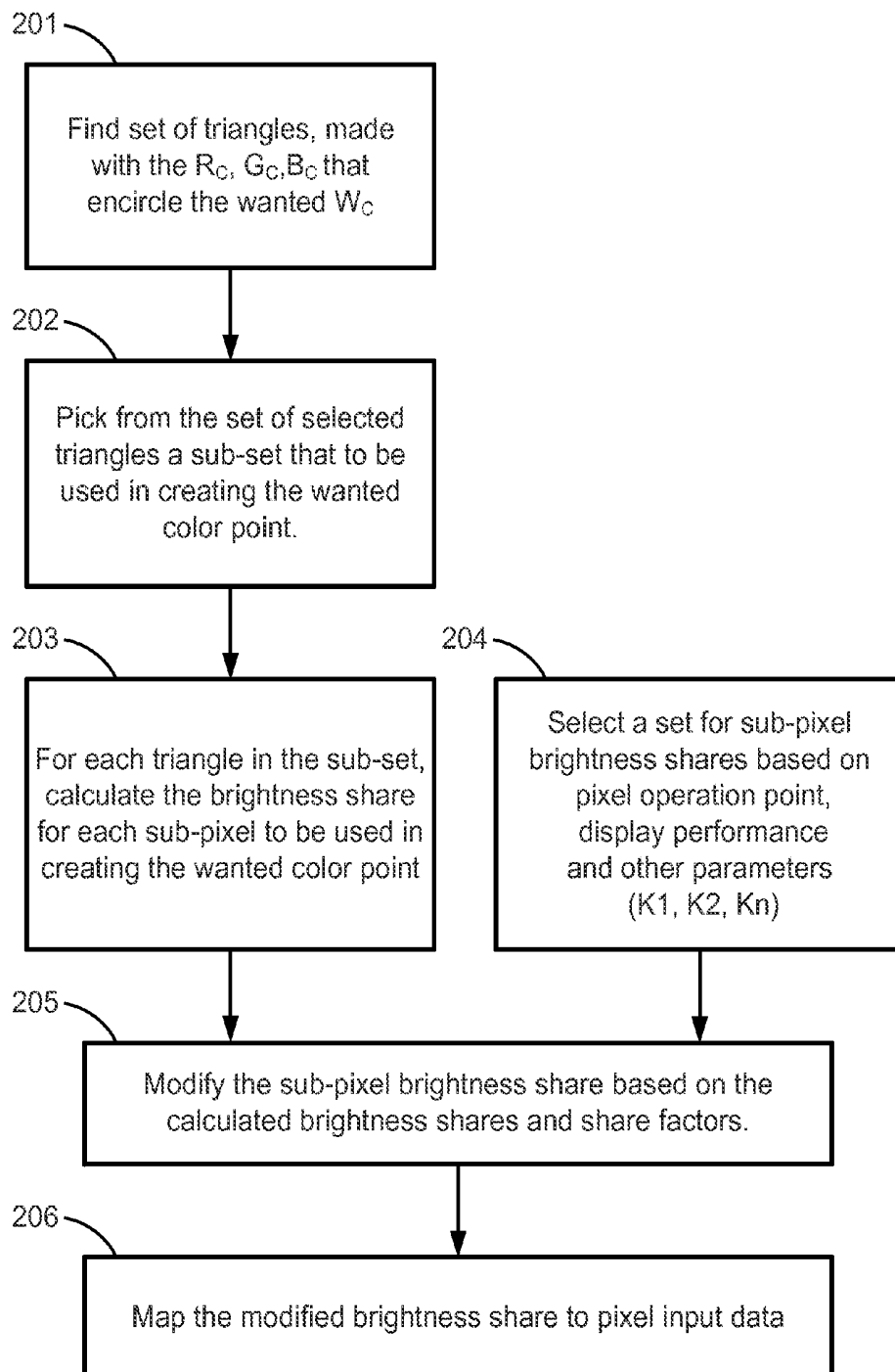

FIG. 2

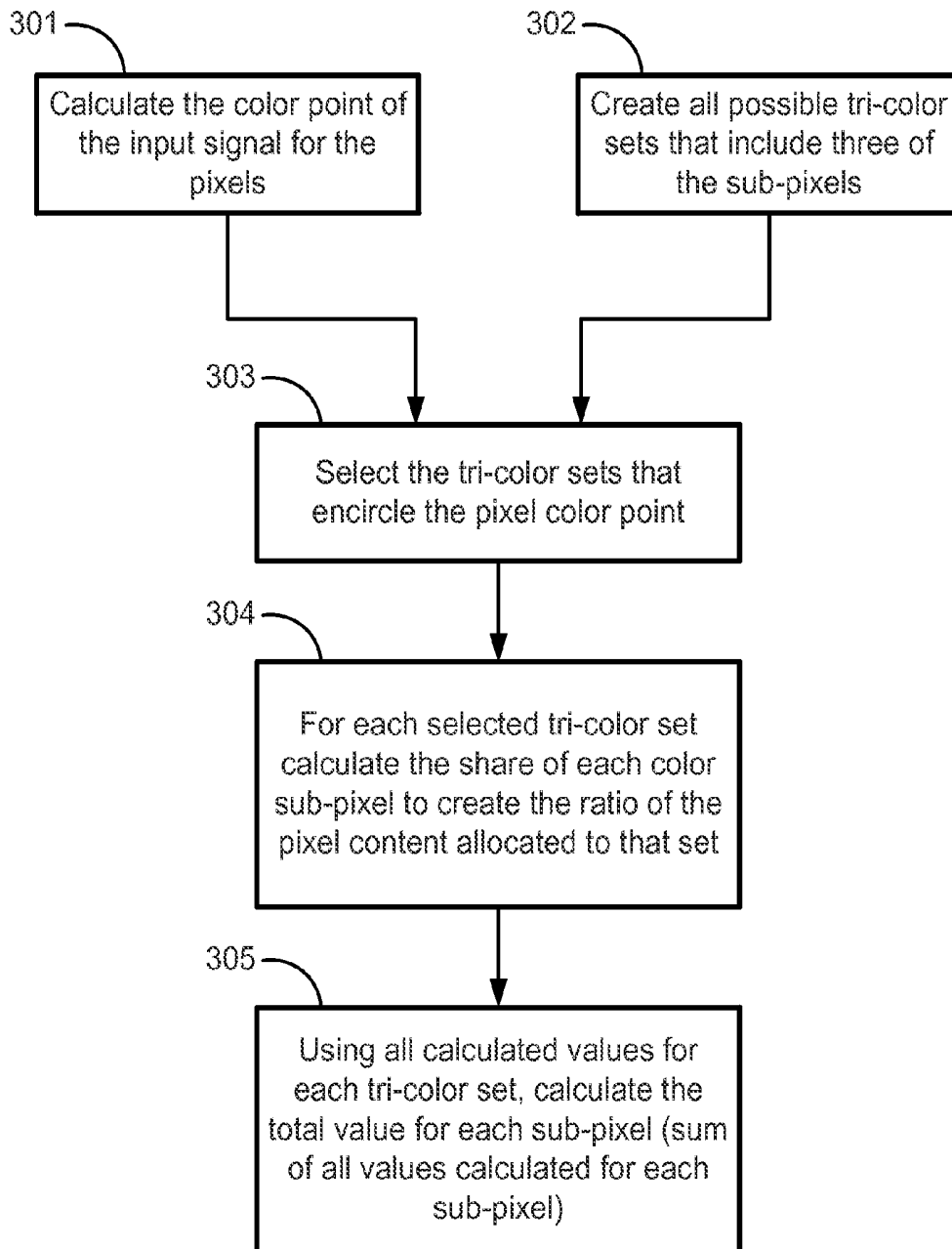

FIG. 3

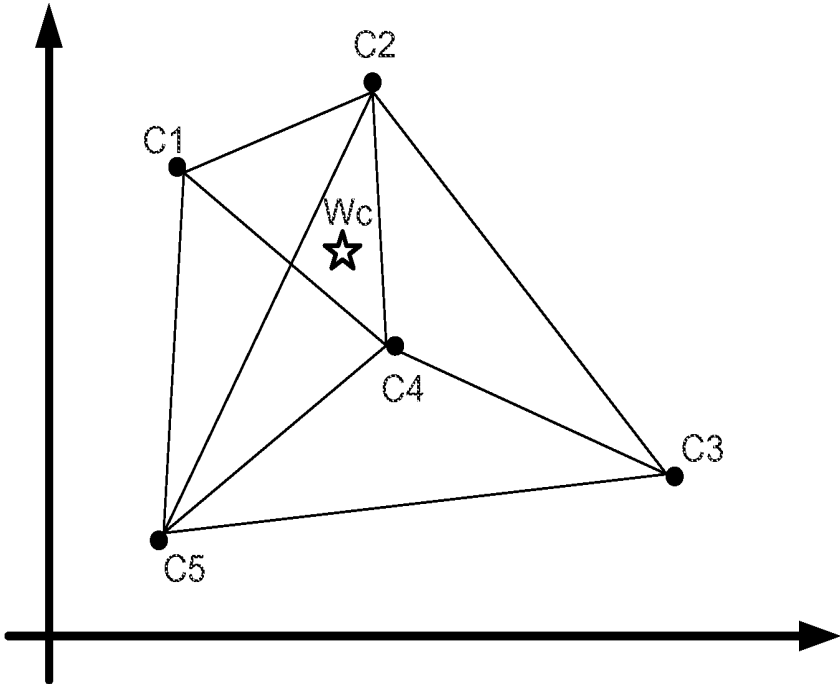

FIG. 4

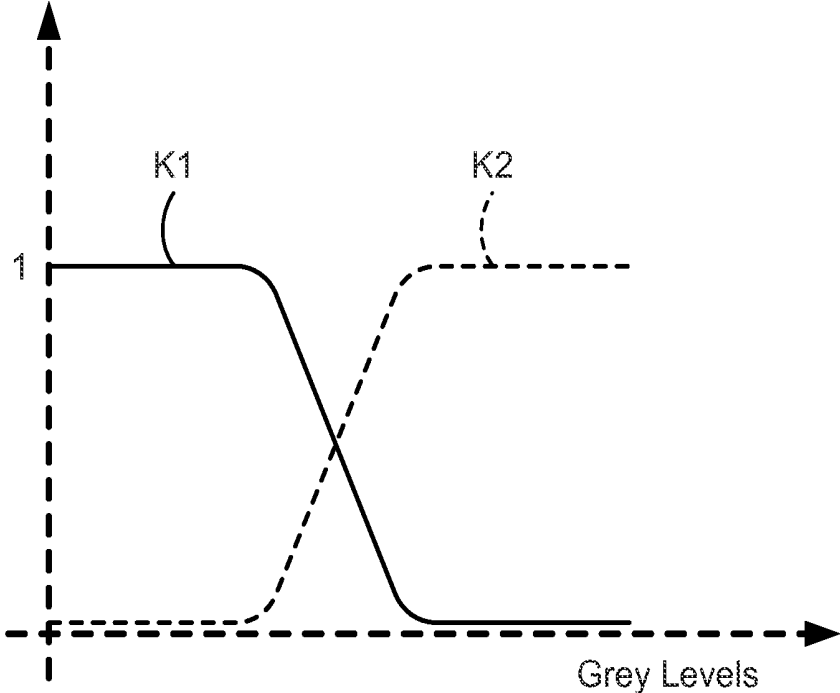

FIG. 5

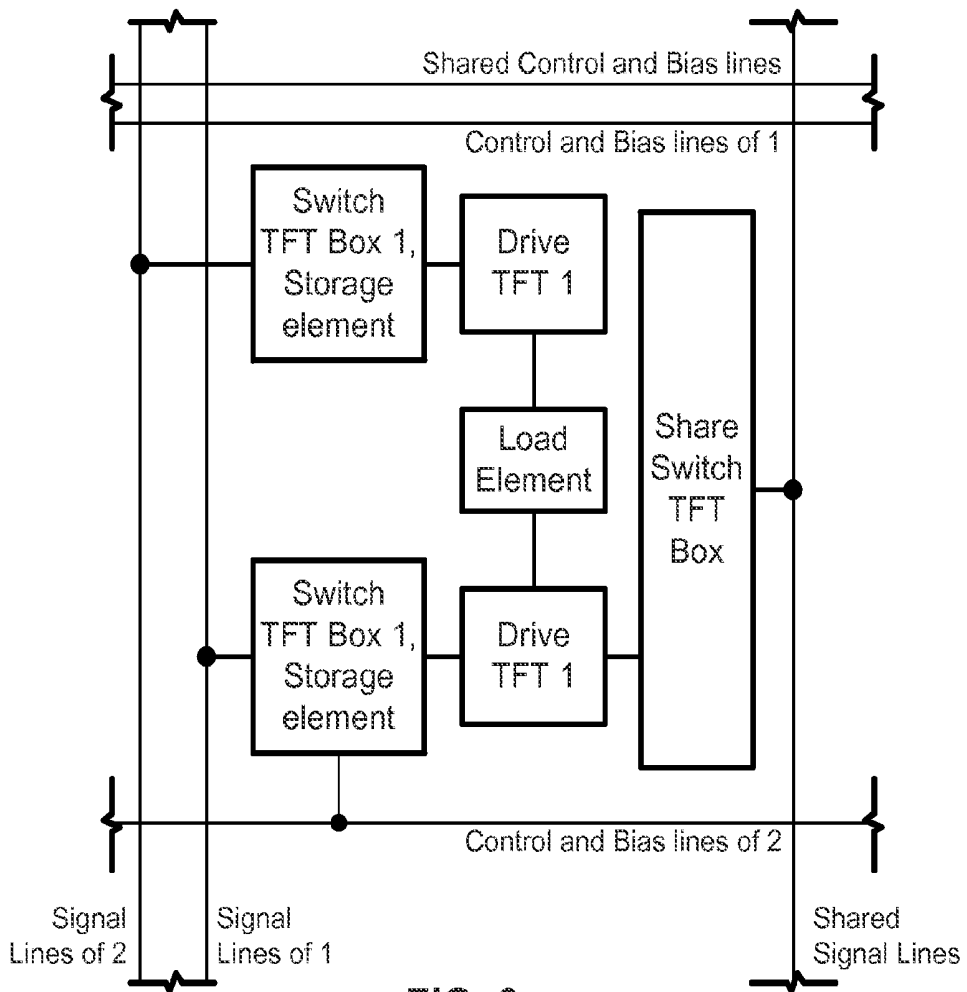

FIG. 6

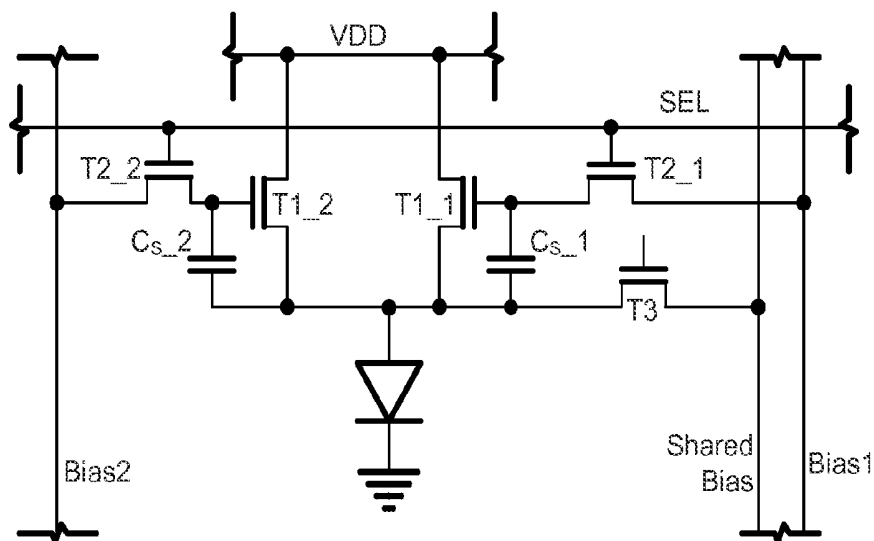

FIG. 7

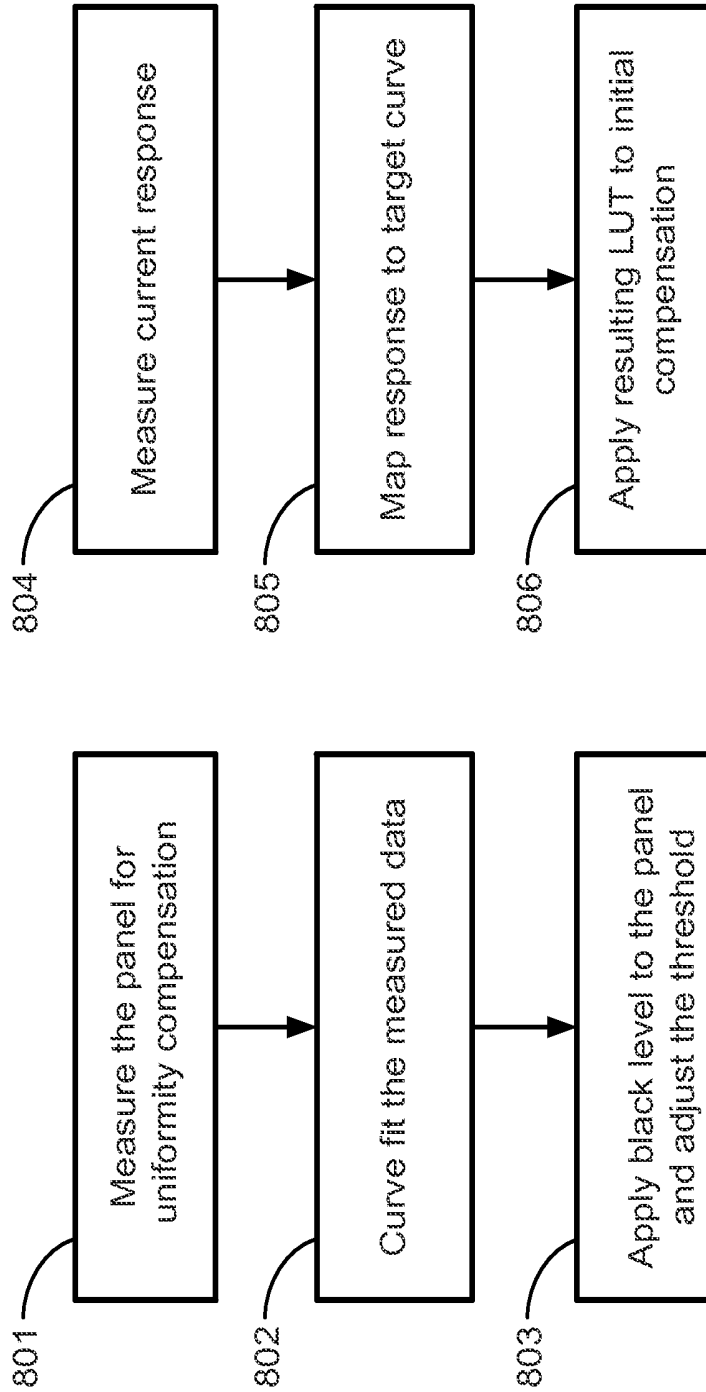

FIG. 8A

FIG. 8B

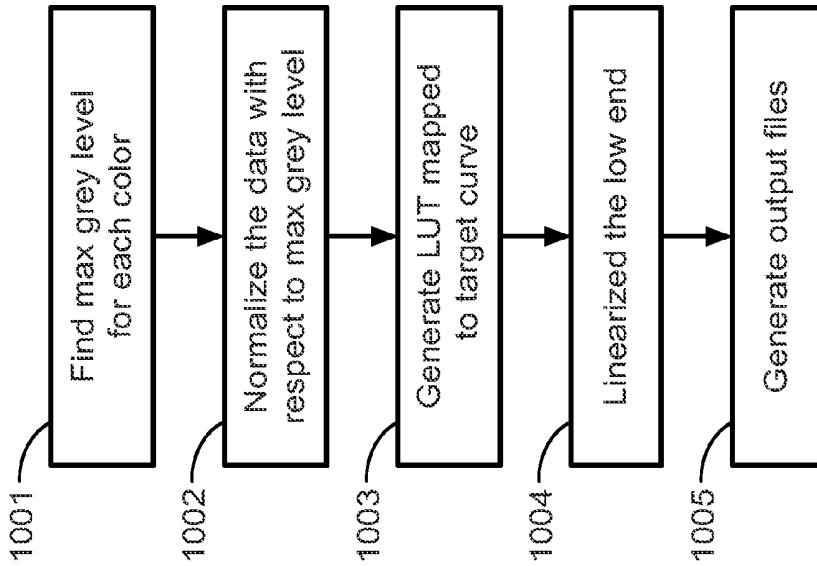

FIG. 10

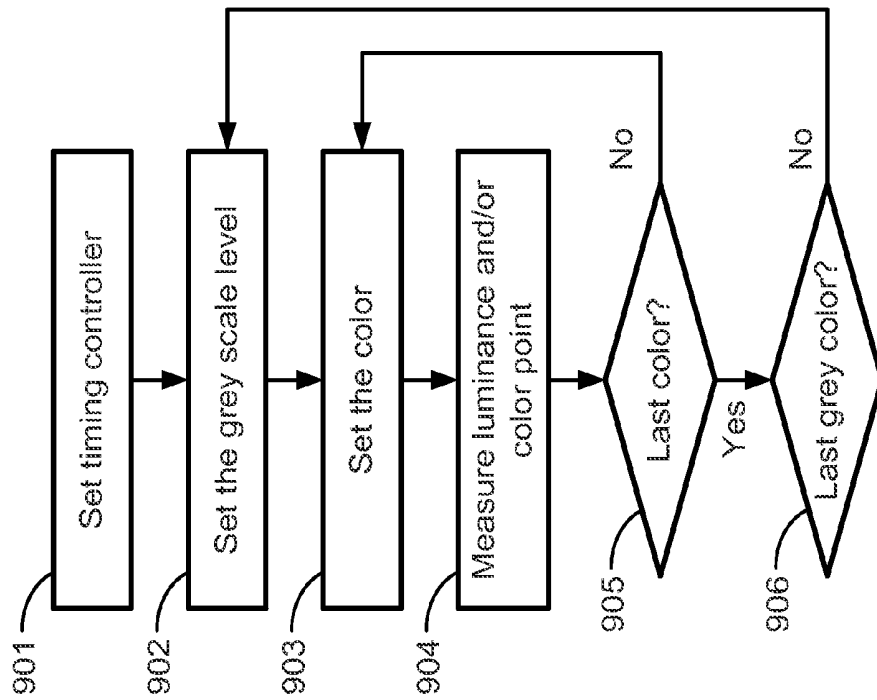

FIG. 9

CROSS REFERENCE TO RELATED APPLICATION

This application claims the benefit of U.S. Provisional Patent Applications Nos. 61/976,909, filed Apr. 8, 2014, and 61/912,786, filed Dec. 6, 2013, each of which is hereby incorporated by reference in its entirety.

FIELD OF THE INVENTION

The present invention relates generally to OLED displays and, more particularly, to an OLED display system and method for improving color accuracy, power consumption or lifetime, and gamma and black level correction of OLED displays that have three or more sub-pixel of different colors and at least one white sub-pixel.

SUMMARY

In accordance with one embodiment, a method and system are provided for controlling an OLED display to achieve desired color points and brightness levels in an array of pixels in which each pixel includes at least three sub-pixels having different colors and at least one white sub-pixel. The method and system select a plurality of reference points in the pixel content domain with known color points and brightness levels. For each set of three sub-pixels of different colors, the method and system determine the share of each sub-pixel to produce the color point and brightness level of each selected reference point, and select the maximum share determined for each sub-pixel as the peak brightness needed from that sub-pixel.

In accordance with another embodiment, the method and system identify tri-color sets of three sub-pixels of different colors that encircle a desired color point, and, for each identified tri-color set of sub-pixels, determine the brightness shares of the sub-pixels in that tricolor set to produce the desired color point. The method and system select a set of share factors based on at least a pixel operation point and display performance, modify the brightness shares based on the share factors, and map the modified brightness shares to pixel input data. In one implementation, The method and system determine the efficiencies of the identified tri-color sets, increase the share factor of the tri-color set with the highest efficiency; decrease the share factor of the tri-color set with the lowest efficiency, as the gray scale of the desired color point increases, and decrease the share factor of the tri-color set with the highest efficiency, and increase the share factor of the tri-color set with the lowest efficiency, as the gray scale of the desired color point decreases.

A further embodiment provides an OLED display comprising an array of pixels in which each pixel includes at least three sub-pixels having different colors and at least one white sub-pixel for displaying desired color points and brightness levels. Each pixel includes at least three sub-pixels having different colors and at least one white sub-pixel, the sub-pixels having operating conditions that vary with the gray level displayed by the sub-pixel. The pixel has at least two sub-pixels for displaying the same color but having operating conditions that vary differently with the gray level being displayed. A controller selects one of the two sub-pixels displaying the same color, in response to a gray level input to that pixel.

The foregoing and other advantages of the invention will become apparent upon reading the following detailed description and upon reference to the drawings.

FIG. 1 is a flow chart of a routine for calculating the peak brightness of each sub-pixel in a display.

FIG. 2 is a flow chart of a routine for calculating the brightness shares for a tri-color set of sub-pixels.

FIG. 3 is a flow chart of a routine for content mapping based on multiple sub-pixel colors in a display.

FIG. 4 is a diagram of a multiple sub-pixel display structure.

FIG. 5 is a graph of an example of share factors as a function of gray levels of a tricolor set with the lowest and highest efficiencies K1 and K2.

FIG. 6 is a block diagram of two locally optimized sub-pixels.

FIG. 7 is an electrical schematic diagram of a pixel circuit having two locally optimized sub-pixels.

FIG. 8A is a flow chart of a procedure for adjusting the black level of a display panel based on panel uniformity measurements.

FIG. 8B is a flow chart of a procedure for using a measured current response to determine a lookup table for initial compensation of a display panel.

FIG. 9 is a flow chart of a current response measurement procedure.

FIG. 10 is a flow chart of a map response to target curve procedure.

While the invention is susceptible to various modifications and alternative forms, specific embodiments have been shown by way of example in the drawings and will be described in detail herein. It should be understood, however, that the invention is not intended to be limited to the particular forms disclosed. Rather, the invention is to cover all modifications, equivalents, and alternatives falling within the spirit and scope of the invention as defined by the appended claims.

DETAILED DESCRIPTION

Sub-Pixel Mapping

To improve color accuracy, power consumption or lifetime, OLED displays may have more than three primary sub-pixel colors. Therefore, proper color mapping is needed to provide continuous color space despite transitions between different color elements. Each pixel in such OLED displays consists of n sub-pixels $\{SP_1, SP_2, SP_3 \dots SP_n\}$. The peak brightness that each sub-pixel should be able to create can be calculated, and used for the design of the display or for adjusting the gamma levels to required levels.

FIG. 1 is a flow chart of an exemplary routine for calculating the peak brightness for each sub-pixel. The first step **101** selects a plurality of reference points, with known color and brightness, such as peak white points, in the pixel content domain. Step **102** identifies all possible tri-color sets that include three of the sub-pixels. Then for each tri-color set, step **103** calculates the share of each sub-pixel to create the reference content point, i.e., the color and brightness. Step **104** selects the maximum value for each sub-pixel, from all the calculated shares, as the peak brightness that needs to be provided that sub-pixel.

The following is an example of calculating the brightness shares for a tri-color set of sub-pixels for a given white point and peak brightness:

```

function [Green Red Blue] = Color_Sharing_RGB (Rc, Gc, Bc, Wc)
%% Rc, Gc, Bc the color points of the tri-color sets
%% Wc is the white color point
L = 100; %% Peak Brightness
%% calculating the brightness share
WM= [Wc(1)-1    0    Wc(1);
      0          1    0;
      Wc(2)      0    Wc(2) ];
LM= [-Wc(1)*L;
      L;
      -(Wc(2)-1)*L];
x = inx (WM);
Wt = x * LM;
Mt = [Gc(1)/(Gc(2))      Rc(1)/(Rc(2))      Bc(1)/(Bc(2));
      1                  1                  1
      (1-Gc(1)-Gc(2))/Gc(2)  (1-Rc(1)-Rc(2))/Rc(2)  (1-Bc(1)-
      Bc(2))/Bc(2)];
x2 = inx (Mt) ;
CR = x2 * Wt; %% CR is the brightness share of the trio-color set.
Green = CR(1);
Red = CR(2);
Blue = CR(3);
end

```

FIG. 2 is a flow chart of an exemplary routine for calculating the brightness shares for the sub-pixels in a tri-color set. The first step 201 finds a set of triangles, made with the tri-color sub-pixels Rc, Gc, Bc that encircle a wanted white point Wc. Step 202 then selects a sub-set of those triangles to be used in creating the wanted color point Wc. Then for each triangle in the subset of triangles, step 203 calculates the brightness share for each sub-pixel in each triangle to create the wanted color point Wc. Step 204 selects a set of sub-pixel brightness shares based on a pixel operation point, display performance and other parameters (K1, K2 . . . Kn). Step 205 then uses the outputs of steps 203 and 204 to modify the sub-pixel brightness shares, based on the calculated brightness shares and share factors. Finally, step 206 maps the modified brightness shares to the pixel input data.

Different standards exist for characterizing colors. One example is the 1931 CIE standard, which characterizes colors by a luminance (brightness) parameter and two color coordinates x and y. The coordinates x and y specify a point on a CIE chromaticity diagram, which represents the mapping of human color perception in terms of the two CIE parameters x and y. The colors that can be matched by combining a given set of three primary colors, such as red, green and blue, are represented by a triangle that joins the coordinates for the three colors, within the CIE chromaticity diagram.

The following is an example of the brightness shares: The parameters x and y for the color points of the tri-color set and intended white point are as follows:

Rc=[0.66 0.34]

Bc=[0.14 0.15]

Gc=[0.38 0.59]

Wc=[0.31 0.33]

[Green Red Blue]=Color_Sharing_RGB (Rc, Gc, Bc, Wc)

The color shares for the tri-color set are as follows:

Green=59.8237%

Red=17.7716%

Blue=22.4047%

Each of the tri-color sets that encircles the pixel content will create a share of the pixel contents K_1, K_2, \dots, K_m , where the K_i 's are the shares of the respective sub-pixels in each tri-color set in the pixel content. The value of each sub-pixel in each of the tri-color sets is calculated considering the share of each tri-color. One such method is based on the

function illustrated in FIG. 3, where step 301 calculates the color point of the input signal for the pixels, and step 302 creates all possible tri-color sets that include three of the sub-pixels. Step 303 then selects the tri-color sets that encircle the pixel color point, and step 304 calculates the share of each color sub-pixel to create the ratio of the pixel content allocated to each selected tri-color set. Step 305 uses all the calculated values for each tri-color set to calculate the total value for each sub-pixel, e.g., the sum of all values calculated for each sub-pixel.

FIG. 4 shows an example of a display incorporating more than three sub-pixel colors (C1, C2, C3, C4, C5) and a wanted color point of Wc. As can be seen, the color point Wc can be created by any of {C1, C2, C4}, {C2, C4, C5}, {C2, C3, C5}, and {C1, C2, C3}. To create the wanted color Wc, one can use the algorithm described above. Also, one can use share factors to create the wanted color based on the sum of all the sets, such as:

$$Wc = K1 * \{C1, C2, C4\} + K2 * \{C2, C4, C5\} + K3 * \{C2, C3, C5\} + K4 * \{C1, C2, C3\},$$

where the K_i 's are the share factors for the tri-color set.

Dynamic Share Factor Adjustment

The share of each tri-color set can be varied based on the pixel content. For example, some sets provide better characteristics (e.g., uniformity) at some grayscales, whereas other sets can be better for other characteristics (e.g., power consumption) at different grayscales.

In one example, a display consists of Red, Green, Blue and White sub-pixels. The white sub-pixel is very efficient and so it can provide lower power consumption at high brightness. However, due to higher efficiency, the non-uniformity compensation does not work well at lower gray scales. In this case, low gray scales can be created with less efficient sub-pixels (e.g., red, green, and blue). Thus, the share factor can be a function of gray scales to take advantage of different set strengths at each gray level. For example, the share factor of a tri-color set with the lowest efficiency ($K1$) can be reduced at higher gray levels and increased at lower gray scales. And the share factor of the tri-color set with the highest efficiency ($K2=1-K1$) can be increased as the gray scale increases. Thus, the display can have both lower-power consumption at higher brightness levels and higher-uniformity at lower gray scales. This function can be step, a linear function or any other complex function. However, a smoothing function can be used at

large transitions to avoid contours. FIG. 5 shows an example of the share factors for a two tri-color set system.

Locally Optimized Sub-Pixels

Due to the wide range of specifications for display performance, the sub-pixels will have an optimum operation point, and diverging from that point can affect one or two specifications. For example, to achieve low power consumption, one can use drive TFTs that are as large as possible to reduce the operating voltage. On the other hand, at low current levels, the TFTs will operate in a non-optimized regime of operation (e.g., sub-threshold). On the other hand, using small TFTs to improve the low grayscale performance will affect the power consumption and lifetime due to using large operating currents.

To address the difficulty in having a single sub-pixel optimized across all gray levels and operation ranges (e.g. different environmental conditions, brightness levels, etc), one can add sub-pixels optimized for different operating ranges. To optimize the operation of each sub-pixel for a specific gray-level set, one can change the component size or use a different pixel circuit for each locally optimized sub-pixel. Here, one can share all or some components of the sub-pixel (e.g., OLEDs, bias transistors, bias lines, and others). FIG. 6 illustrates an example using two locally optimized sub-pixels with some shared components and some dedicated components to each sub-pixel. Also, one can have two different load elements (e.g., OLEDs). In this example, the current required for either shared load or combined separate load elements is generated by both sub-pixels 1 and 2 where $I_1 = A_1 * I$ and $I_2 = A_2 * I$ (I is the total current required for the load, I_1 is the current generated by sub-pixel #1, I_2 is the current generated by sub-pixel #2, and $A_2 = (1 - A_1)$). Here, A_1 and A_2 are adjusted for different gray-scales (or operating conditions) to adjust the ratio of each sub-pixel in generating the current.

One can add sub-pixels optimized for different operating ranges. Here, one can share all or some components of the pixel (e.g., OLED, bias transistors, bias lines, and others).

FIG. 7 is a circuit diagram of an exemplary embodiment in which the drive TFT (T1), the programming switch TFT (T2), and the storage element (C_s) are optimized for each sub-pixel. Also, the TFT T3, the bias line, the select line (SEL) and the power line (VDD) are shared. In one case, different sizes of drive TFTs can be used to optimize the sub-pixels for different ranges of operation. For example, one can use a smaller drive TFT for one sub-pixel to be used for lower gray scales, and a larger drive TFT for the other sub-pixel to be used for higher gray scales.

Selecting each sub-pixel can be done either through a switch that activates or deactivates the sub-pixel, or through programming a sub-pixel with an off voltage to deactivate it.

The locally optimized sub-pixel method can be used for all sub-pixels or for only selected sub-pixels. For example, in the case of a RGBW sub-pixel structure, optimizing white sub-pixels across all gray levels is very difficult due to high OLED efficiency, while other sub-pixels can be optimized more easily. Thus, one can use a locally optimized sub-pixel method only for the white sub-pixel.

Gamma and Black Level Correction

A gamma calibration procedure ensures that colors displayed by a panel are accurate to the desired gamma curve, usually 2.2. The procedure has now been largely automated. The target white-point and curve are parameterized. The high level process is shown in FIGS. 8A and 8B. This procedure assumes that initial uniformity compensation for the panel has already been applied.

In the procedure of FIG. 8A, step 801 measures the display panel for uniformity compensation, and then curve fits the measured data. A black level is applied to the panel, and the threshold parameter for each sub-pixel is adjusted until the panel is black. In the procedure of FIG. 8B, the current response is measured at step 804, and then mapped to a target curve in step 805. Step 806 applies the resulting lookup table to initial compensation.

One advantage of emissive displays is deep black level. However, due to the non-linear behavior of the pixels and non-uniformity in the pixels, it is difficult to achieve black levels based on a continuous gamma curve. In one method, the worst case is chosen, and the off voltage is calculated based on that. Then that voltage, with some margin, is assigned to the black gray level, which generally puts the panel in a deep negative biasing condition. Since some backplanes are sensitive to negative bias conditions, the panel will develop image burn-in and non-uniformity over time.

To avoid that, the black level can be adjusted based on panel uniformity information. In this case, the uniformity of the pixel is measured at step 801 in FIG. 8A, and the threshold voltage (at which the pixel current is assumed to be off) is calculated at step 802. However, since simplified models are used to reduce the calculation and compensation complexity, the calculated threshold voltage will have some error. To assign a black voltage, the threshold voltage of the pixel is reduced at step 803 until the panel turns black. This can be done for each color individually, and the new modified threshold voltage is used for black voltage level.

In another aspect of this invention, a plurality of sensors are added to the panel, and the voltage of the black level is adjusted until all sensors provide zero readings. In this case, the initial start of the black level can be the calculated threshold voltage.

In another aspect of this invention, the black level for each sensor is adjusted individually, and a map of black level voltage is created based on each sensor data. This map can be created based on different methods of interpolation.

In another aspect of the invention, the black level has at least two values. One value is used for dark environments and another value is used for bright environments. Since the lower black level is not useful in bright environments, the pixel can be slightly on (at a level that is less than or similar to the reflection of the panel). Therefore, the pixel can avoid negative stress which is accelerated under higher brightness levels.

In another aspect of the invention, the black level has at least two values. One value is used when all the sub-pixels are off, and another value is used when at least one sub-pixel is ON. In this case, there can be a threshold for the brightness level of the ON sub-pixels required to switch to the second black level value for the OFF sub-pixels. For example, if the blue sub-pixel is ON and its brightness is higher than 1 nit, the other sub-pixels can be slightly ON (for example, less than 0.01 nit). In this case, the OFF sub-pixels can eliminate the negative bias stress under illumination.

In another aspect of the invention, the brightness of neighboring sub-pixel can be used to switch between different black level values. In this case, a weight can be assigned to the sub-pixels based on their distance from the OFF sub-pixels. In one example, this weight can be a fixed value, dropping to zero after a distance of a selected number of pixels. In another example, the weight can be a linear drop from one to zero. Also, different complex functions can be used for the weight function.

Measure Current Response

The steps for a measure-current-response process are summarized in FIG. 9. The initial step 901 sets a timing controller, which ensures that measurements are taken with the display in the correct mode. Specifically, it ensures that the most recent compensation is being displayed on the panel. It also ensures that TFT and OLED corrections required before a gamma function is applied, are enabled while gamma correction and luminance correction are disabled. To avoid having to write the entire frame buffer to a single value, special flat-field registers can be implemented in the timing controller. When the timing controller is placed in this mode, step 902 writes the desired grey scale to the corresponding colors register, which is sufficient to display the desired color. Since characterizing the panel, especially at higher levels, with the entire panel on can lead to lower brightness and/or current limiting, step 903 sets only part of the panel to show the desired color level.

As pre-set list of grey scales is used to determine the measurement points that will be used. In one implementation, a list of 61 levels is used for characterization. These points are not linearly spaced; they are positioned more densely toward the low end of the curve, becoming sparser as the grey level increases. This is done to generally fit a 2.2 curve, not a linear one, and can be adjusted for other gamma curves. The list is ordered from the lowest target level (e.g., 0) to the highest target (e.g., 1023). Also, it can be in any other order. After applying each color level, the resulting luminance and/or color point (CIE-XY) are then recorded at step 904. Multiple measurements are taken, and error checking is employed to ensure the validity of the readings. For example, if the variation in the reading is too great, the setup is not working properly. Or if the reading shows an increasing or decreasing trend, it means the values have not settled yet. If luminance only is measured by a calibrated sensor, these readings are converted to luminance and color point data during processing based on a calibration curve of the sensor. The order of steps can be changed and still obtain valid results. Steps 903 and 904 are repeated until the last color is detected at step 905, after which steps 902-905 are repeated until the last gray color is detected at step 906.

Map Response to Target Curve

The target curve (e.g., the required gamma response) and white-point are specified as input parameters to the mapping function. The steps of this process are summarized in FIG. 10.

The first step is to load the measured data from the generated by the characterization procedure. If the data to be processed is from a calibrated sensor, one additional step is required. The calibration files for the sensor are used to convert the raw sensor readings to luminance and color point values.

Once the data is loaded, the target color point and peak luminance are used to calculate the peak target luminance for each color. Step 1001 finds the grey scale which results in this luminance, which allows the new maximum grey scale for each color to be determined. If any of the colors are not able to achieve the target, the target is adjusted such that the highest achievable brightness is targeted instead. Then the luminance readings are normalized to one, with respect to this new maximum grey scale, at step 1002.

This normalized data can now be used to map the measurements to the target curve, generating a look up table at step 1003. Linear interpolation is used to estimate the luminance between the measurement points. However, different known curve fitting processes can be used as well. The target curve is created by normalizing the target curve and

finding the values for each of the points from lowest gray level (e.g., 0) to the highest gray level (e.g., 1023).

Some cases, like the standard sRGB curve, are actually piece wise. In these cases, a different component is used for each part of the curve. For example, for the standard sRGB, there is a linear component at the low end while the remainder of the curve is exponential. As a result, linearization is applied to the low end of the lookup table at step 1004. The point where linearization needs to be applied can be extracted from mapping the measured data to the standard. For example, the linearization can be applied to the first 100 grey scales where gray 100 represents the brightness points that the standard identifies and the change in the curve.

After the linearization is applied, all that remains is to write the resulting lookup table (LUT) to the appropriate output formats, at step 1005.

While particular embodiments and applications of the present invention have been illustrated and described, it is to be understood that the invention is not limited to the precise construction and compositions disclosed herein and that various modifications, changes, and variations can be apparent from the foregoing descriptions without departing from the spirit and scope of the invention as defined in the appended claims.

The invention claimed is:

1. A method of controlling an OLED display to achieve desired color points and brightness levels in an array of pixels in which each pixel includes at least three sub-pixels having different colors and at least one white sub-pixel, said method comprising

selecting a plurality of reference points in a pixel content domain with known color points and brightness levels, identifying all possible tri-color sets of three sub-pixels from the at least three sub-pixels having different colors and the at least one white sub-pixel;

for each tri-color set of three sub-pixels, determining a share of each sub-pixel to produce the color point and brightness level of each selected reference point, and selecting the maximum share determined for each sub-pixel as the peak brightness needed for that sub-pixel.

2. The method of claim 1 wherein the at least three sub-pixels having different colors of each pixel comprises red, green and blue sub-pixels.

3. A system for controlling an OLED display to achieve desired color points and brightness levels in an array of pixels in which each pixel includes at least three sub-pixels having different colors and at least one white sub-pixel, said system comprising

a processor configured to

select a plurality of reference points in a pixel content domain with known color points and brightness levels,

identify all possible tri-color sets of three sub-pixels from the at least three sub-pixels having different colors and the at least one white sub-pixel,

determine, for each tri-color set of three sub-pixels, a share of each sub-pixel to produce the color point and brightness level of each selected reference point, and

select the maximum share determined for each sub-pixel as the peak brightness needed for that sub-pixel.

4. The system of claim 3 wherein the at least three sub-pixels having different colors of each pixel comprises red, green and blue sub-pixels.

5. A method of controlling an OLED display to achieve desired color points and brightness levels in an array of pixels in which each pixel includes at least three sub-pixels having different colors and at least one white sub-pixel, said method comprising

identifying two or more tri-color sets of three sub-pixels of different colors that encircle a desired color point, for each identified tri-color set of sub-pixels, determining the brightness shares of the sub-pixels in that tricolor set to produce the desired color point,
 for each identified tri-color set of sub-pixels, selecting a set of share factors based on at least one of a pixel operation point and display performance,
 modifying said brightness shares based on said share factors, and
 mapping the modified brightness shares to pixel input data.

6. The method of claim 5 which includes determining the efficiencies of the identified tri-color sets, increasing the set share factor of one of the tri-color sets with the highest efficiency,
 decreasing the set share factor of one of the tri-color sets with the lowest efficiency, as the gray scale of the desired color point increases, and
 decreasing the share factor of the tri-color set with the highest efficiency, and increasing the share factor of the tri-color set with the lowest efficiency, as the gray scale of the desired color point decreases.

7. The method of claim 5 in which each tricolor set of sub-pixels of different colors is a set of red, green and blue sub-pixels.

8. A system for controlling an OLED display to achieve desired color points and brightness levels in an array of pixels in which each pixel includes at least three sub-pixels having different colors and at least one white sub-pixel, said system comprising

a processor configured to
 identify two or more tri-color sets of three sub-pixels of different colors that encircle a desired color point,
 determine, for each identified tri-color set of sub-pixels, the brightness shares of the sub-pixels in that tricolor set to produce the desired color point,
 select, for each identified tri-color set of sub-pixels, a set share factor based on at least one of: a pixel operation point and display performance,
 modify said brightness shares based on said set share factors, and
 map the modified brightness shares to pixel input data.

9. The system of claim 8 which said processor is configured to:

determine the efficiencies of the identified tri-color sets, increase the set share factor of one of the tri-color sets with the highest efficiency, and decrease the set share

factor of one of the tri-color sets with the lowest efficiency, as the gray scale of the desired color point increases, and

decrease the set share factor of the tri-color set with the highest efficiency, and increase the set share factor of the tri-color set with the lowest efficiency, as the gray scale of the desired color point decreases.

10. The system of claim 8 in which each tri-color set of sub-pixels of different colors is a set of red, green and blue sub-pixels.

11. A method of controlling an OLED display to achieve desired color points and brightness levels in an array of pixels in which each pixel includes at least three sub-pixels having different colors and at least one white sub-pixel, said method comprising

determining the color point of an input signal for a selected pixel,
 identifying all tri-color sets of three sub-pixels of different colors,
 selecting two or more tri-color sets that encircle said color point of said input signal,
 for each selected tri-color set of sub-pixels, determining brightness shares of the three sub-pixels of that tri-color set to produce said color point of said input signal,
 selecting, for each identified tri-color set of sub-pixels, a set share factor based on at least one of: a pixel operation point and display performance,
 modifying said brightness shares based on said set share factors, and
 mapping the modified brightness shares to pixel input data.

12. The method of claim 11 in which each tri-color set of sub-pixels of different colors is a set of red, green and blue sub-pixels.

13. An OLED display comprising
 an array of pixels in which each pixel includes at least three sub-pixels having different colors and at least one white sub-pixel for displaying desired color points and brightness levels,
 said sub-pixels having operating conditions that vary with the gray level displayed by the sub-pixel,
 said pixel having at least two sub-pixels for displaying the same color but having operating conditions that vary differently with the gray level being displayed, and

a controller for selecting one of the two sub-pixels displaying the same color, in response to a gray level input to that pixel.

14. The OLED display of claim 13 wherein the at least three sub-pixels having different colors of each pixel comprises red, green and blue sub-pixels.

* * * * *

专利名称(译)	OLED显示系统和方法		
公开(公告)号	US9741282	公开(公告)日	2017-08-22
申请号	US14/561404	申请日	2014-12-05
[标]申请(专利权)人(译)	伊格尼斯创新公司		
申请(专利权)人(译)	IGNIS创新INC.		
当前申请(专利权)人(译)	IGNIS创新INC.		
[标]发明人	GIANNIKOURIS ALLYSON SONI JAIMAL ZAHIROVIC NINO NGAN RICKY YIK HEI CHAJI GHOLAMREZA		
发明人	GIANNIKOURIS, ALLYSON SONI, JAIMAL ZAHIROVIC, NINO NGAN, RICKY YIK HEI CHAJI, GHOLAMREZA'		
IPC分类号	G09G3/20 G09G3/3208 G09G3/3233		
CPC分类号	G09G3/2074 G09G3/2003 G09G3/3208 G09G3/3233 G09G2300/0452 G09G2300/0852 G09G2320/0238 G09G2320/0276 G09G2320/0673 G09G2330/021 G09G2340/06		
代理机构(译)	尼克松皮博迪律师事务所		
优先权	61/976909 2014-04-08 US 61/912786 2013-12-06 US		
其他公开文献	US20150161935A1		
外部链接	Espacenet USPTO		

摘要(译)

一种方法和系统控制OLED显示器以在像素阵列中实现期望的色点和亮度级，其中每个像素包括具有不同颜色的至少三个子像素和至少一个白色子像素。该方法和系统利用已知的色点和亮度级选择像素内容域中的多个参考点。对于每组不同颜色的三个子像素，该方法和系统确定每个子像素的份额以产生每个所选参考点的色点和亮度级别，并选择为每个子像素确定的最大份额为孩子像素所需的峰值亮度。

